



RODIX INCORPORATED

TOLL FREE (800) 562-1868, FAX (815) 316-4701

E-mail custserve@rodix.com

www.rodix.com

FEEDER CUBE®

FC-41-480-KT ALL PURPOSE

OPEN FRAME MODEL

IMPORTANT: APPLICATION NOTE

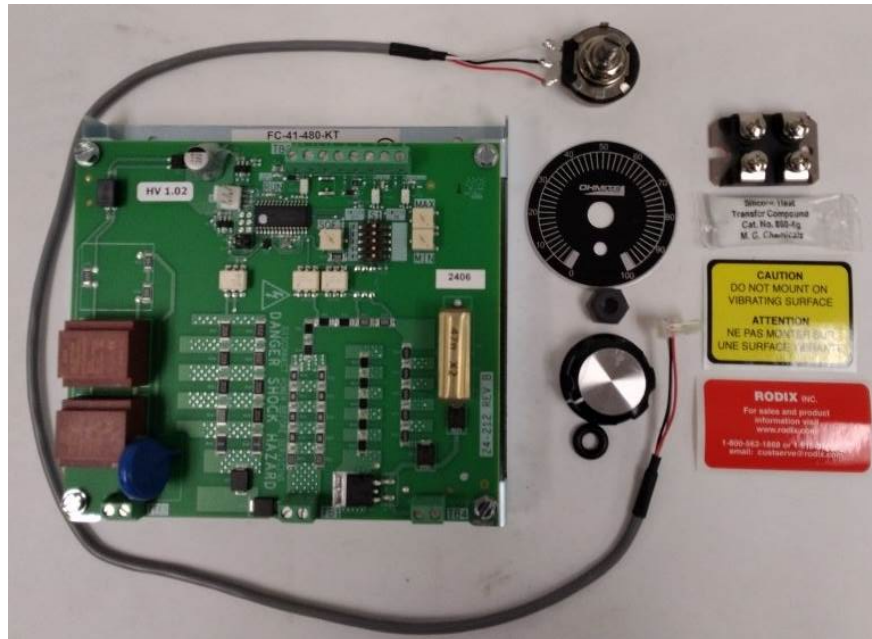



RODIX INC.
FEEDER CUBE®
FC-41-480 Series
Kit



Kit Contents



Bracket Side



Rear View



End View



File No. E183233

Model FC-41-480-KT

P/N 121-000-1127

Circuit Board P/N 24-212

Input: 480 VAC, 50/60 HZ.

(Operating range 270-500 VAC)

Single Unit Fuse Size: Use 30 AMPS Maximum

Output: 0-480 VAC, 0.1 - 18 AMPS

Open Frame

© 2024 RODIX INC.

INSTALLATION

Kit 121-000-1127 is designed to be installed using UL Listed components: enclosure; Disconnect Switch; cords; cord bushings; 600V, 30A fuseholder; 600V, 35A fuses or smaller. Use Recognized Components: wire rated 600V, 105°C; wire connectors suitable for the wire; terminal blocks such as Wago 2004 or similar, rated 600VAC, 30A minimum. Note: The knob tensioning O-ring gets installed under the knob.

ADJUSTMENTS & SET UP

1. SELECT THE PULSE SETTING

Match the control's pulse mode to the feeder's tuning:

- A. For 60 pulse output - Set DIP switch (S1) to 60 on the circuit card.
- B. For 30 pulse settings, see the "S1 Programming Chart."

2. LIMITING THE MAXIMUM OUTPUT OF CONTROL

The **MAX** output trimpot can be adjusted to limit the maximum vibration level of the vibratory feeder when the Main Control Dial is fully turned up. When setting up the **MAX** output of the feeder control, the output wiring to feeder must be connected. The Run Jumper must be connected as shown on the wiring diagram or on the ON/OFF Control Guide.

- A. Power input should be **OFF** or disconnected.
- B. Open cover to allow access to circuit card.
- C. Adjust the **MAX** Output trimpot counter-clockwise to its minimum setting.
- D. Close the cover. Turn power **ON** (no output should be present).
- E. Rotate the **MAIN CONTROL DIAL** on front cover clockwise to its highest setting.
- F. Turn power **OFF** and adjust the **MAX** Output trimpot up about 1/8 to a 1/4 turn. Close cover and reapply power. Repeat step F until the output to the feeder reaches its desired maximum level.

3. SETTING THE MINIMUM OUTPUT LEVEL OF CONTROL

When the vibratory feeder is nearly empty, turn the **MAIN CONTROL DIAL** to "1" and adjust the **MIN** trimpot to just below the slowest speed that provides the proper vibration. The **MIN** trimpot should only be adjusted while the disconnect switch is **OFF**. The **MIN** trimpot also serves as the "low speed" trimpot for

2-speed operation. See "S1 Programming Chart" for feature selection details.

4. MAIN CONTROL DIAL

The output power is controlled by the **MAIN CONTROL DIAL**. It is a logarithmic-tapered power out curve (non-linear) that spreads the power broadly across the **MAIN CONTROL DIAL**. The logarithmic taper power curve helps to give maximum "Fine Control" over the output speed of the vibratory feeder. When very precise adjustment of the **MAIN CONTROL DIAL** is needed, increase the **MIN** trimpot setting and/or decrease the **MAX** trimpot setting.

5. SETTING THE SOFT-START

The start-up rate of the control output can be adjusted to ramp up to the desired output level instead of starting abruptly. Soft-start keeps parts from falling off the tooling, reduces spring shock, and hammering when the control turns ON. Turn the **SOFT** Start trimpot clockwise for the gentlest start (about a 6 sec. ramp up to full output). Turn the trimpot fully counter-clockwise for no soft start.

6. REMOTE OFF/ON CONTROL

A Run Jumper has been installed at the factory as shown on the enclosed wiring diagram.

Remote OFF/ON operation of the control can be configured to operate in one of the following ways.

- A. A **low current switch** such as a paddle switch can replace the factory-installed Run Jumper "J1." The "Run Contact" connects to terminals 6 and 7. The contact must be able to switch 5VDC and 2mA. The control will run only when the contact is closed. Refer to Section A of the OFF/ON CONTROL GUIDE.
- B. **Low Voltage DC** can be used to turn the control **ON** and **OFF**. Move jumper "J1" from terminal 7, to terminal 5, (6 remains the same). Then connect the positive signal (+10 to 30VDC @ 10mA) to terminal 12 and the negative to terminal 11 of TB2. The control will now turn **ON** when the DC signal is present at terminals 11 and 12 of TB2. This input is optically isolated. Refer to Section B of the OFF/ON CONTROL GUIDE.

7. STATUS LEDs

When any of the inputs are active, the associated LED will turn ON. When the RUN input conditions are met, the RUN LED will turn ON. See section 6 and the wiring diagram's ON/OFF Control Guide for more information on how to satisfy the RUN conditions.

8. REMOTE SPEED CONTROL

Remote control of the power level can be accomplished by the following methods:

- A. 4-20mA signal from a PLC can be used to remotely vary the output of the control instead of the Main Control Dial. The 4-20mA input is automatically in control whenever a 4-20mA signal is applied to the control (terminals TB2-8 & 9). The Main Control dial setting is ignored whenever there is a 4-20mA signal. The 4-20mA input is transformer isolated from the power line. In an environment with high electrical noise, use a shielded cable for the 4-20mA signal.
- B. A 0-5VDC Analog input signal may be applied in place of the Main Control Dial at H1. The 0-5VDC input is transformer isolated from the power line.

9. LINE VOLTAGE COMPENSATION

Fluctuations in the line voltage can cause a vibrator to vary its vibration. The line voltage compensation feature adjusts the control's output to help compensate for fluctuations in the supply voltage. Use the accompanying chart to set the line voltage compensation to match the line voltage. If it becomes necessary to disable this feature, set to "no LVC" from the S1 Line Voltage Chart. Note: Only the 575V circuit board contains three identical transformers, the other voltages are covered by a board with two transformers.

S1 Line Voltage Chart			
Line Voltage	S1 Switch Positions		
	SW1	SW2	SW3
480 volts	OFF	OFF	OFF
440 volts	OFF	OFF	ON
415 volts	OFF	ON	OFF
400 volts	OFF	ON	ON
380 volts	ON	OFF	OFF
277 volts	ON	OFF	ON
575 volts	ON	ON	OFF
no LVC	ON	ON	ON

10. SUPPLEMENTARY FEATURES

Special supplementary software features can be enabled on the 24-212 circuit boards. The features include: 30 pulse low pulse rate, low amplitude, and *two speed pots*. See the "S1 Programming Chart". For more feature information download (or request from RODIX) the FC-41-480 Advanced Application Note.

S1 Programming Chart		
Program	S1 Switch Positions	
	SW4	SW5
Standard	OFF	OFF
Low Ampl.	OFF	ON
30 Pulse	ON	OFF
2-Speed	ON	ON

TROUBLESHOOTING

For the control to run: The **MAIN CONTROL DIAL** must be turned up or have over 4mA at the 4-20mA input. Either the **DIRECT LED** must be lit or both the **INTERLOCK** and **EXT VOLTS LEDs** must be on. To light the **DIRECT LED**, connect a Run Jumper at TB2-6 & TB2-7. To light the **INTERLOCK LED**, a Run Jumper must connect TB2-5 to TB2-6. To illuminate the **EXT VOLTS LED**, TB2-11 & 12 needs a 10-30 VDC signal. See the "FC-41-480 Troubleshooting Guide" for more information.

WARNING:

Fuses should be replaced with Ferraz ATDR30 Class CC fuses or smaller amperage Ferraz ATMR fuses. These are "Fast Acting" type fuses.

Mounting this control on a vibrating surface will void the warranty.

WARRANTY

Rodix Control Products are Warranted to be free from defects in material and workmanship under normal use for a period of two years from date of shipment. For the full description of the warranty, terms, and software license, please contact the factory.

For assistance installing or operating your Rodix Feeder Cube® please call the factory or visit our web site. Technical help is available to answer your questions and

email any needed information. To return a control for IN or OUT of warranty service, please ship it prepaid to:

Rodix Inc., ATTN: Repair Department

If under warranty, Rodix will repair or replace your control at no charge; If out of warranty, we will repair it and you will be billed for the repair charges (Time and Material) plus the return freight. Quotes for repairs are available upon request. A brief note describing the symptoms helps our technicians address the issue.

Feeder Cube® is a registered TM of Rodix Inc.

DIMENSIONS

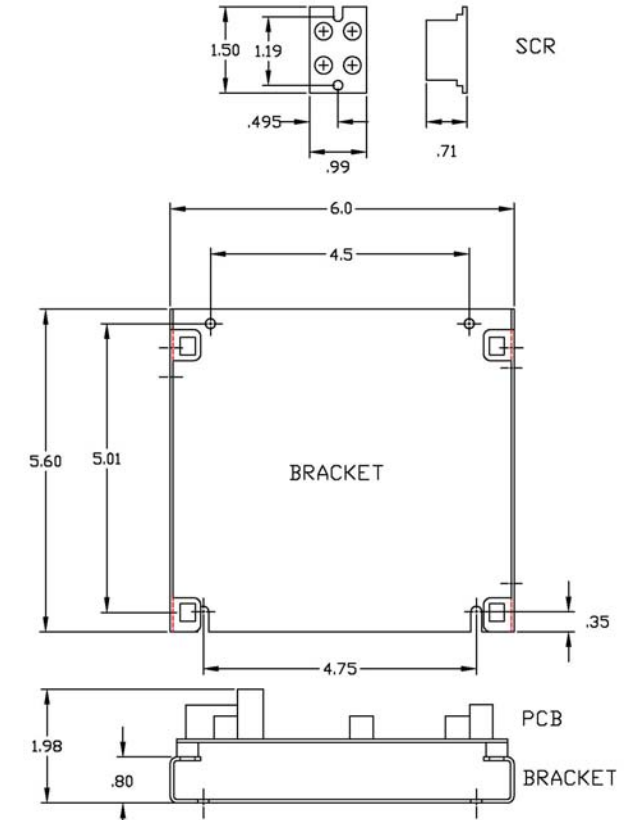

RODIX, INC.

2316 23rd Ave., Rockford, IL 61104
Toll Free (800) 562-1868, FAX (815) 316-4701
E-mail custserve@rodix.com

www.rodix.com

FC-41-480-KT 121-000-1127.docx 6/11/2024

Page 2

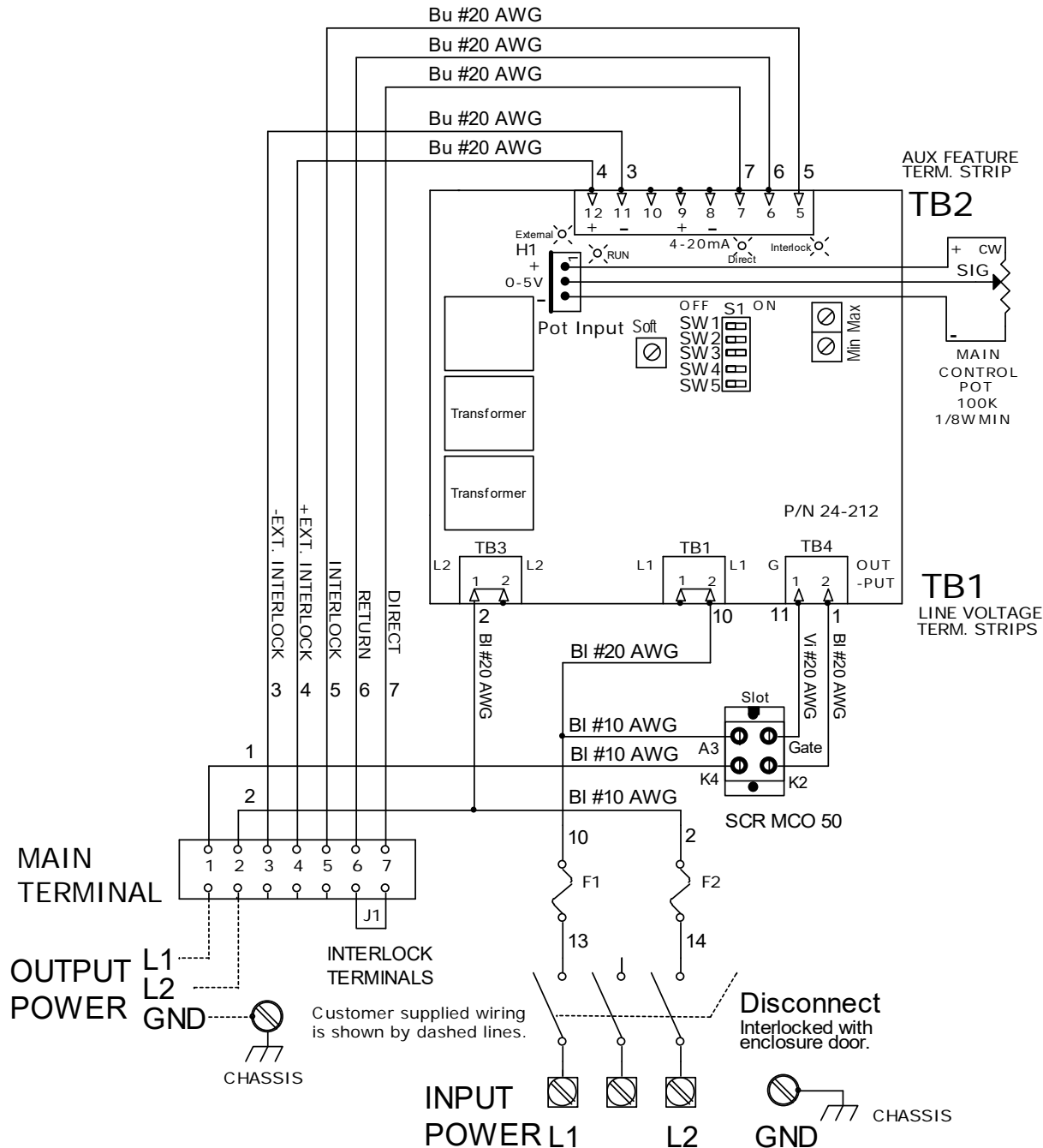

OFF/ON CONTROL GUIDE

See section 6 of the Application Note for more details on the REMOTE OFF/ON CONTROL guide.

A) LOW CURRENT SWITCH

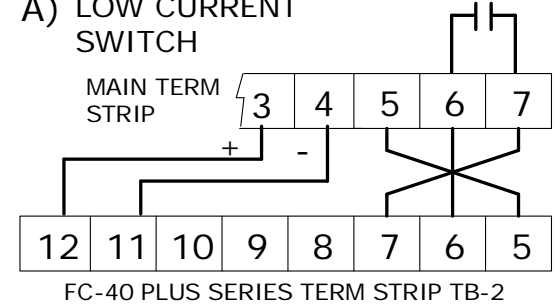

B) LOW VOLTAGE INPUT SWITCHING (DC Voltage from PLC)

10-30 VDC INPUT VOLTAGE
 OFF/ON CONTROL

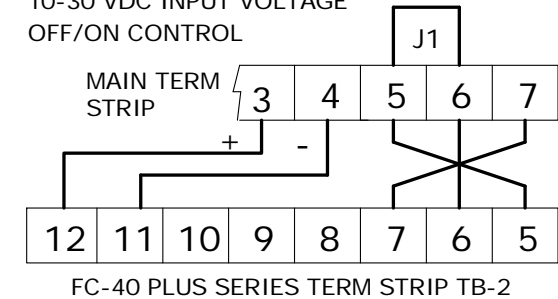

RODIX, INC.

2316 23rd Ave., Rockford, IL 61104
 Toll Free (800) 562-1868, FAX (815) 316-4701
 Email custserve@rodix.com

www.rodix.com

FC-41-480-KT 121-000-1127.docx 6/11/2024

MODEL	INPUT VAC	AMPS	OUTPUT
FC-41-480-KT	480 VAC	0.1 - 20 Max.	~0-90% of INPUT